

CS221 Problem Workout

Week 2

Key Takeaways from this Week

The goal of ML is to learn a function f parameterized by w s.t. $f_w(x)$ is very close to y . Each algorithm is a triplet of three design decisions:

1. **Hypothesis class** – How will I write down my prediction for y as a function of x ? Which parameters w do I need to learn?
2. **Loss function** – How do I measure how far my prediction is from the real y ?
3. **Optimization algorithm** – What algorithm will I use to minimize my loss function?

		Hypothesis class	Loss function	Optimization algorithm
$y \in \mathbb{R}$	Linear regression	$f_w(x) := w \cdot \phi(x)$	Squared loss: $(f_w(x) - y)^2$	GD or SGD
$y \in \{-1, 1\}$	(Binary) linear classification	$f_w(x) := \text{sign}(w \cdot \phi(x))$	0-1 loss: $1[f_w(x) \neq y]$	Cannot use GD, SGD
			Hinge loss: $\max\{1 - (w \cdot \phi(x))y, 0\}$	GD or SGD
			Logistic loss: $\log(1 + e^{-(w \cdot \phi(x))y})$	GD or SGD

Dimension check. Above, $w, \phi(x) \in \mathbb{R}^d$, while y is a scalar.

1) Problem 1: Non-linear features

Consider the following two training datasets of (x, y) pairs:

- $\mathcal{D}_1 = \{(-1, +1), (0, -1), (1, +1)\}$.
- $\mathcal{D}_2 = \{(-1, -1), (0, +1), (1, -1)\}$.

Observe that neither dataset is linearly separable if we use $\phi(x) = x$, so let's fix that.

Define a two-dimensional feature function $\phi(x)$ such that:

- There exists a weight vector \mathbf{w}_1 that classifies \mathcal{D}_1 perfectly (meaning that $\mathbf{w}_1 \cdot \phi(x) > 0$ if x is labeled $+1$ and $\mathbf{w}_1 \cdot \phi(x) < 0$ if x is labeled -1); and
- There exists a weight vector \mathbf{w}_2 that classifies \mathcal{D}_2 perfectly.

Note that the weight vectors can be different for the two datasets, but the features $\phi(x)$ must be the same.

Some additional food for thought: Is every dataset linearly separable in some feature space? In other words, given pairs $(\mathbf{x}_1, y_1), \dots, (\mathbf{x}_n, y_n)$, can we find a feature extractor ϕ such that we can perfectly classify $(\phi(\mathbf{x}_1), y_1), \dots, (\phi(\mathbf{x}_n), y_n)$ for some linear model \mathbf{w} ? If so, is this a good feature extractor to use?

2) Problem 2: Backpropagation

Consider the following function

$$\text{Loss}(x, y, z, w) = 2(xy + \max\{w, z\})$$

Run the backpropagation algorithm to compute the four gradients (each with respect to one of the individual variables) at $x = 3$, $y = -4$, $z = 2$ and $w = -1$. Use the following nodes: addition, multiplication, max, multiplication by a constant.

3) Problem 3: K-means

Consider doing ordinary K -means clustering with $K = 2$ clusters on the following set of 3 one-dimensional points:

$$\{-2, 0, 10\}. \tag{1}$$

Recall that K -means can get stuck in local optima. Describe the precise conditions on the initialization $\mu_1 \in \mathbb{R}$ and $\mu_2 \in \mathbb{R}$ such that running K -means will yield the global optimum of the objective function. Notes:

- Assume that $\mu_1 < \mu_2$.
- Assume that if in step 1 of K -means, no points are assigned to some cluster j , then in step 2, that centroid μ_j is set to ∞ .
- Hint: try running K -means from various initializations μ_1, μ_2 to get some intuition; for example, if we initialize $\mu_1 = 1$ and $\mu_2 = 9$, then we converge to $\mu_1 = -1$ and $\mu_2 = 10$.

4) [optional] Problem 4: Non-linear decision boundaries

Suppose we are performing classification where the input points are of the form $(x_1, x_2) \in \mathbb{R}^2$. We can choose any subset of the following set of features:

$$\mathcal{F} = \left\{ x_1^2, x_2^2, x_1 x_2, x_1, x_2, \frac{1}{x_1}, \frac{1}{x_2}, 1, \mathbf{1}[x_1 \geq 0], \mathbf{1}[x_2 \geq 0] \right\} \quad (2)$$

For each subset of features $F \subseteq \mathcal{F}$, let $D(F)$ be the set of all decision boundaries corresponding to linear classifiers that use features F .

For each of the following sets of decision boundaries E , provide the minimal F such that $D(F) \supseteq E$. If no such F exists, write ‘none’.

For example the set of features $F = \{x_1^2, x_2\}$ allows the decision boundary of parabolas opening in the x_2 axis, centered at the origin:

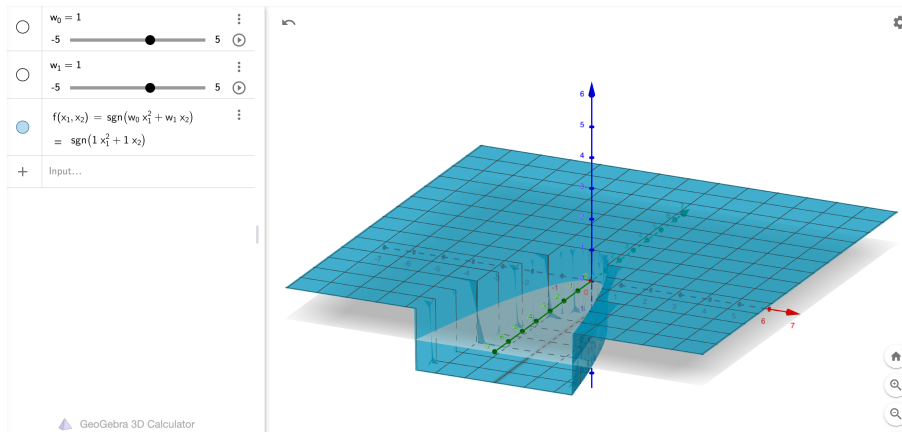

- E is all lines [CA hint]:
_____ (3)

- E is all circles centered at the origin:
_____ (4)

- E is all circles:
_____ (5)

- E is all axis-aligned rectangles:
_____ (6)

- E is all axis-aligned rectangles whose lower-right corner is at $(0, 0)$:
_____ (7)